

# HEF40244B

## Octal buffers with 3-state outputs

Rev. 4 — 29 June 2018

Product data sheet

## 1 General description

The HEF40244B is an octal non-inverting buffer with 3-state outputs. It features output stages with high current output capability suitable for driving highly capacitive loads.

The 3-state outputs are controlled by the output enable inputs  $\overline{EOA}$  and  $\overline{EOB}$ . A HIGH on  $\overline{EOA}$  or  $\overline{EOB}$  causes the outputs to assume a high impedance OFF-state. The device also features hysteresis on all inputs to improve noise immunity.

Schmitt-trigger action in the inputs makes the circuit highly tolerant to slower input rise and fall times.

## 2 Features and benefits

- Octal bus interface
- 3-state buffers
- Fully static operation
- 5 V, 10 V, and 15 V parametric ratings
- Standardized symmetrical output characteristics
- Specified from  $-40\text{ }^{\circ}\text{C}$  to  $+85\text{ }^{\circ}\text{C}$

## 3 Ordering information

Table 1. Ordering information

Type number	Package			
	Temperature range	Name	Description	Version
HEF40244BT	$-40\text{ }^{\circ}\text{C}$ to $+85\text{ }^{\circ}\text{C}$	SO20	plastic small outline package; 20 leads; body width 7.5 mm	SOT163-1

## 4 Functional diagram

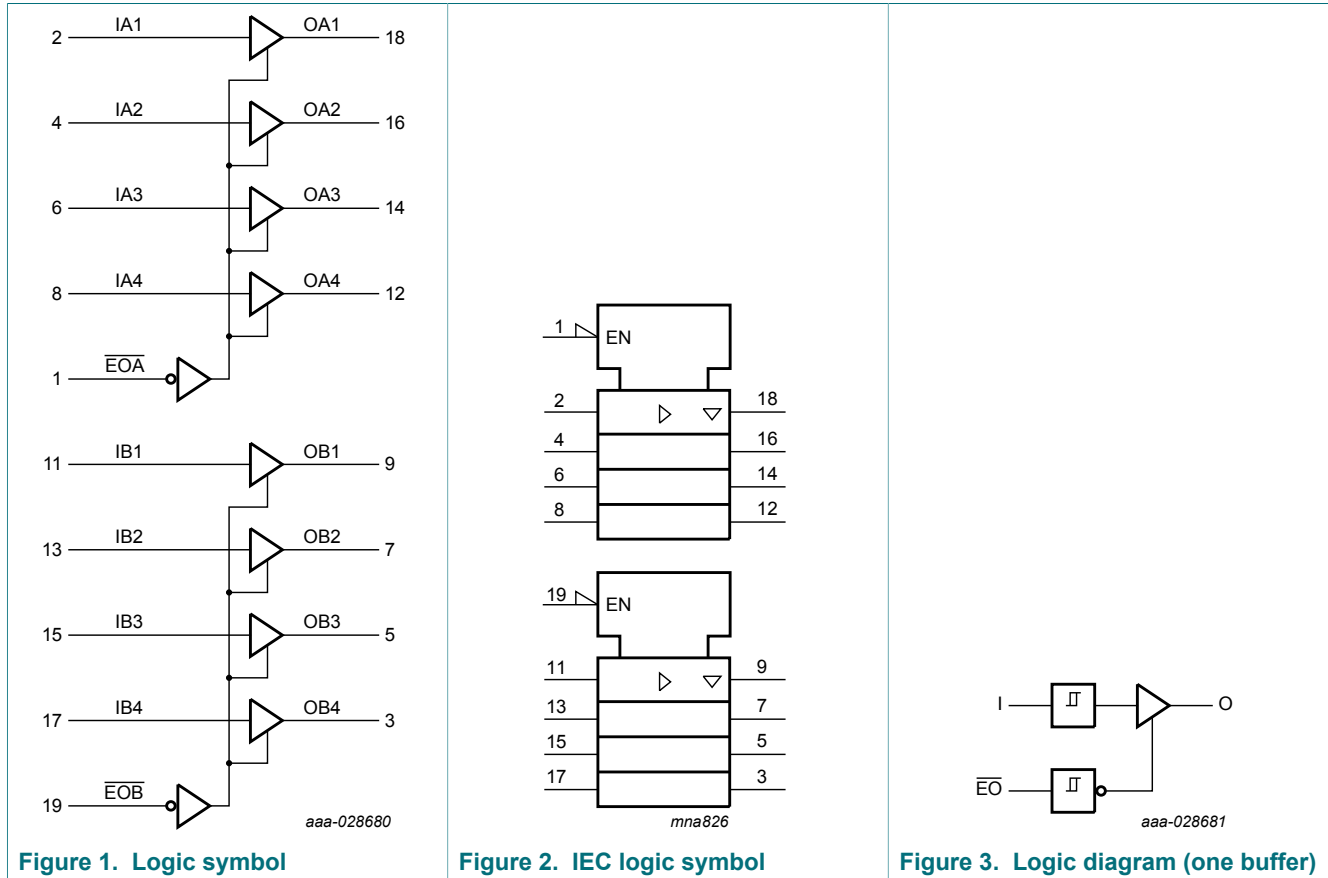

## 5 Pinning information

### 5.1 Pinning

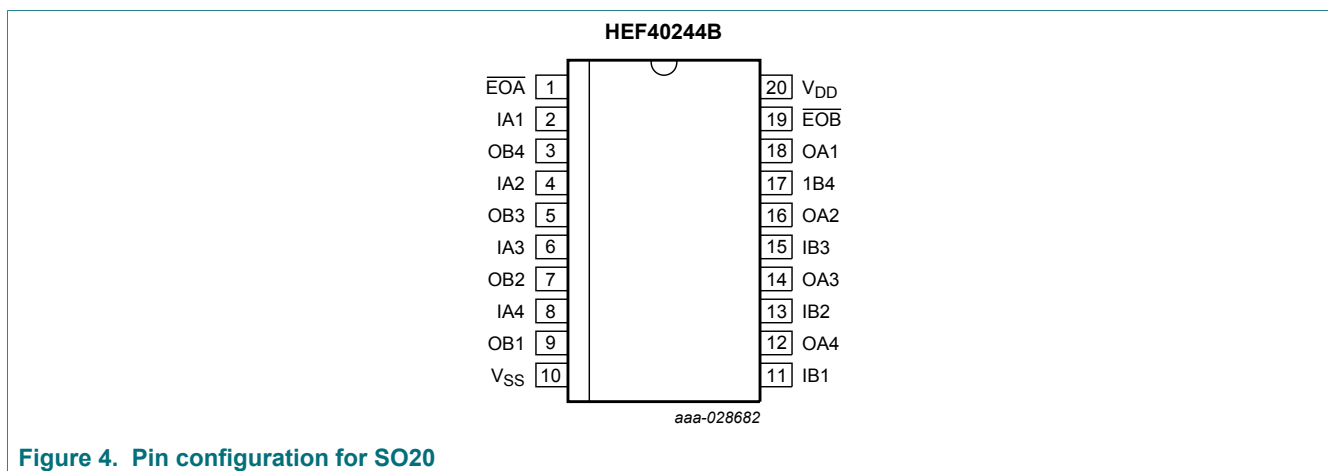

## 5.2 Pin description

Table 2. Pin description

Symbol	Pin	Description
$\overline{EOA}$ , $\overline{EOB}$	1, 19	output enable inputs (active low)
IA1, IA2, IA3, IA4	2, 4, 6, 8	data inputs
OA1, OA2, OA3, OA4	18, 16, 14, 12	data outputs
IB1, IB2, IB3, IB4	11, 13, 15, 17	data inputs
OB1, OB2, OB3, OB4	9, 7, 5, 3	data outputs
$V_{SS}$	10	ground supply voltage
$V_{DD}$	20	supply voltage

## 6 Functional description

Table 3. Function table <sup>[1]</sup>

Control	Input	Output
$\overline{EOA}$ or $\overline{EOB}$	IAn or IBn	OAn or OBn
L	L	L
L	H	H
H	X	Z

[1] H = HIGH voltage level;  
 L = LOW voltage level;  
 X = don't care;  
 Z = high-impedance OFF-state.

## 7 Limiting values

Table 4. Limiting values

In accordance with the Absolute Maximum Rating System (IEC 60134).

Symbol	Parameter	Conditions	Min	Max	Unit
$V_{DD}$	supply voltage		-0.5	+18	V
$V_I$	input voltage		-0.5	$V_{DD} + 0.5$	V
$I_{DD}$	supply current		-	±100	mA
$I_{IK}$	input clamping current		-	±10	mA
$I_{OK}$	output clamping current		-	±25	mA
$T_{stg}$	storage temperature		-65	+150	°C
$T_{amb}$	ambient temperature		-40	+85	°C
$P_{tot}$	total power dissipation	$T_{amb} = -40\text{ °C to }+85\text{ °C}$			
		SO20 package <sup>[1]</sup>	-	500	mW
P	power dissipation	per output	-	100	mW

[1] For SO20 package:  $P_{tot}$  derates linearly with 8 mW/K above 70 °C.

## 8 Recommended operating conditions

Table 5. Operating conditions

Symbol	Parameter	Conditions	Min	Max	Unit
$V_{DD}$	supply voltage	referenced to $V_{SS}$ (usually ground)	3	15	V
$V_I$	input voltage		0	$V_{DD}$	V
$T_{amb}$	ambient temperature	in free air	-40	+85	°C
$\Delta t/\Delta V$	input transition rise and fall rate	$V_{DD} = 5\text{ V}$	-	3.75	$\mu\text{s/V}$
		$V_{DD} = 10\text{ V}$	-	0.5	$\mu\text{s/V}$
		$V_{DD} = 15\text{ V}$	-	0.08	$\mu\text{s/V}$

## 9 Static characteristics

Table 6. Static characteristics

$V_{SS} = 0\text{ V}$ ;  $V_I = V_{SS}$  or  $V_{DD}$  unless otherwise specified.

Symbol	Parameter	Conditions	$T_{amb} = -40\text{ °C}$			$T_{amb} = 25\text{ °C}$			$T_{amb} = 85\text{ °C}$		Unit
			$V_{DD}$	Min	Max	Min	Typ	Max	Min	Max	
$V_{IH}$	HIGH-level input voltage	$ I_O  < 1\ \mu\text{A}$									
		$V_O = 0.5\text{ V}$ or $4.5\text{ V}$	5 V	3.5	-	3.5	-	-	3.5	-	V
		$V_O = 1.0\text{ V}$ or $9.0\text{ V}$	10 V	7.0	-	7.0	-	-	7.0	-	V
		$V_O = 1.5\text{ V}$ or $13.5\text{ V}$	15 V	11.0	-	11.0	-	-	11.0	-	V
$V_{IL}$	LOW-level input voltage	$ I_O  < 1\ \mu\text{A}$									
		$V_O = 0.5\text{ V}$ or $4.5\text{ V}$	5 V	-	1.5	-	-	1.5	-	1.5	V
		$V_O = 1.0\text{ V}$ or $9.0\text{ V}$	10 V	-	3.0	-	-	3.0	-	3.0	V
		$V_O = 1.5\text{ V}$ or $13.5\text{ V}$	15 V	-	4.0	-	-	4.0	-	4.0	V
$V_{OH}$	HIGH-level output voltage	$ I_O  < 1\ \mu\text{A}$	5 V	4.95	-	4.95	-	-	4.95	-	V
			10 V	9.95	-	9.95	-	-	9.95	-	V
			15 V	14.95	-	14.95	-	-	14.95	-	V
$V_{OL}$	LOW-level output voltage	$ I_O  < 1\ \mu\text{A}$	5 V	-	0.05	-	-	0.05	-	0.05	V
			10 V	-	0.05	-	-	0.05	-	0.05	V
			15 V	-	0.05	-	-	0.05	-	0.05	V
$I_{OH}$	HIGH-level output current	see <a href="#">Figure 5</a> and <a href="#">Figure 6</a>									
		$V_{OH} = 3.6\text{ V}$	5 V	-9.3	-	-10	-24	-	-10.7	-	mA
		$V_{OH} = 4.6\text{ V}$	5 V	-0.75	-	-0.6	-1.2	-	-0.45	-	mA
		$V_{OH} = 8.4\text{ V}$	10 V	-14.4	-	-15	-46	-	-15	-	mA
		$V_{OH} = 9.5\text{ V}$	10 V	-1.85	-	-1.5	-3.0	-	-1.1	-	mA
		$V_{OH} = 13.2\text{ V}$	15 V	-19.5	-	-20	-62	-	-19.8	-	mA
	$V_{OH} = 13.5\text{ V}$	15 V	-14.5	-	-15	-50	-	-15.5	-	mA	

Symbol	Parameter	Conditions	T <sub>amb</sub> = -40 °C			T <sub>amb</sub> = 25 °C			T <sub>amb</sub> = 85 °C		Unit
			V <sub>DD</sub>	Min	Max	Min	Typ	Max	Min	Max	
I <sub>OL</sub>	LOW-level output current	V <sub>OL</sub> = 0.4 V	5 V	2.9	-	2.3	5.4	-	1.75	-	mA
		V <sub>OL</sub> = 0.5 V	10 V	9.5	-	7.6	17	-	5.5	-	mA
		V <sub>OL</sub> = 1.5 V	15 V	30.0	-	25	45	-	19.0	-	mA
I <sub>I</sub>	input leakage current	[1]	15 V	-	±0.3	-	-	±0.3	-	±1.0	µA
I <sub>OZ</sub>	OFF-state output current	V <sub>O</sub> = V <sub>DD</sub>	15 V	-	1.6	-	-	1.6	-	12.0	µA
		V <sub>O</sub> = V <sub>SS</sub>	15 V	-	-1.6	-	-	-1.6	-	-12.0	µA
I <sub>DD</sub>	supply current	I <sub>O</sub> = 0 A	5 V	-	4.0	-	-	4.0	-	30	µA
			10 V	-	8.0	-	-	8.0	-	60	µA
			15 V	-	16.0	-	-	16.0	-	120	µA
V <sub>H</sub>	hysteresis voltage		5 V	-	-	-	220	-	-	-	mV
			10 V	-	-	-	250	-	-	-	mV
			15 V	-	-	-	320	-	-	-	mV
C <sub>I</sub>	input capacitance			-	-	-	7.5	-	-	-	pF

[1] Unused inputs must be connected to V<sub>DD</sub>, V<sub>SS</sub> or another input.

## 10 Dynamic characteristics

**Table 7. Dynamic characteristics**

V<sub>SS</sub> = 0 V; T<sub>amb</sub> = 25 °C; unless otherwise specified; for waveform and test circuit, see [Figure 10](#).

Symbol	Parameter	Conditions	Extrapolation formula	Min	Typ	Max	Unit
t <sub>PHL</sub>	HIGH to LOW propagation delay	I <sub>AN</sub> to O <sub>AN</sub> ; I <sub>BN</sub> to O <sub>BN</sub> ; see <a href="#">Figure 7</a> . [1]					
		V <sub>DD</sub> = 5 V	83 ns + (0.24 ns/pF)C <sub>L</sub>	-	95	190	ns
		V <sub>DD</sub> = 10 V	35 ns + (0.10 ns/pF)C <sub>L</sub>	-	40	80	ns
		V <sub>DD</sub> = 15 V	26 ns + (0.07 ns/pF)C <sub>L</sub>	-	30	60	ns
t <sub>PLH</sub>	LOW to HIGH propagation delay	I <sub>AN</sub> to O <sub>AN</sub> ; I <sub>BN</sub> to O <sub>BN</sub> ; see <a href="#">Figure 7</a> . [1]					
		V <sub>DD</sub> = 5 V	82 ns + (0.06 ns/pF)C <sub>L</sub>	-	85	170	ns
		V <sub>DD</sub> = 10 V	38 ns + (0.03 ns/pF)C <sub>L</sub>	-	40	80	ns
		V <sub>DD</sub> = 15 V	29 ns + (0.02 ns/pF)C <sub>L</sub>	-	30	60	ns

Symbol	Parameter	Conditions	Extrapolation formula	Min	Typ	Max	Unit
t <sub>PZH</sub>	OFF-state to HIGH propagation delay	EOA to OAn; EOB to OBn; see <a href="#">Figure 9</a> .					
		V <sub>DD</sub> = 5 V		-	80	160	ns
		V <sub>DD</sub> = 10 V		-	35	70	ns
		V <sub>DD</sub> = 15 V		-	30	60	ns
t <sub>PZL</sub>	OFF-state to LOW propagation delay	EOA to OAn; EOB to OBn; see <a href="#">Figure 9</a> .					
		V <sub>DD</sub> = 5 V		-	90	180	ns
		V <sub>DD</sub> = 10 V		-	40	80	ns
		V <sub>DD</sub> = 15 V		-	30	60	ns
t <sub>PHZ</sub>	HIGH to OFF-state propagation delay	EOA to OAn; EOB to OBn; see <a href="#">Figure 9</a> .					
		V <sub>DD</sub> = 5 V		-	70	140	ns
		V <sub>DD</sub> = 10 V		-	35	70	ns
		V <sub>DD</sub> = 15 V		-	30	60	ns
t <sub>PLZ</sub>	LOW to OFF-state propagation delay	EOA to OAn; EOB to OBn; see <a href="#">Figure 9</a> .					
		V <sub>DD</sub> = 5 V		-	75	150	ns
		V <sub>DD</sub> = 10 V		-	40	80	ns
		V <sub>DD</sub> = 15 V		-	30	60	ns
t <sub>THL</sub>	HIGH to LOW output transition time	OAn; OBn; see <a href="#">Figure 7</a> and <a href="#">Figure 8</a> .					
		V <sub>DD</sub> = 5 V		-	40	80	ns
		V <sub>DD</sub> = 10 V		-	20	40	ns
		V <sub>DD</sub> = 15 V		-	15	30	ns
t <sub>TLH</sub>	LOW to HIGH output transition time	OAn; OBn; see <a href="#">Figure 7</a> and <a href="#">Figure 8</a> .					
		V <sub>DD</sub> = 5 V		-	30	60	ns
		V <sub>DD</sub> = 10 V		-	20	40	ns
		V <sub>DD</sub> = 15 V		-	15	30	ns

[1] The typical values of the propagation delay are calculated from the extrapolation formulas shown (C<sub>L</sub> in pF).

**Table 8. Dynamic power dissipation**

Symbol	Parameter	V <sub>DD</sub>	Typical formula	where:
P <sub>D</sub>	dynamic power dissipation	5 V	$P_D = 4250 \times f_i + \Sigma(f_o \times C_L) \times V_{DD}^2$ (μW)	f <sub>i</sub> = input frequency in MHz; f <sub>o</sub> = output frequency in MHz; C <sub>L</sub> = output load capacitance in pF; Σ(f <sub>o</sub> × C <sub>L</sub> ) = sum of the outputs; V <sub>DD</sub> = supply voltage in V.
		10 V	$P_D = 17000 \times f_i + \Sigma(f_o \times C_L) \times V_{DD}^2$ (μW)	
		15 V	$P_D = 46000 \times f_i + \Sigma(f_o \times C_L) \times V_{DD}^2$ (μW)	

10.1 Waveforms and test circuit

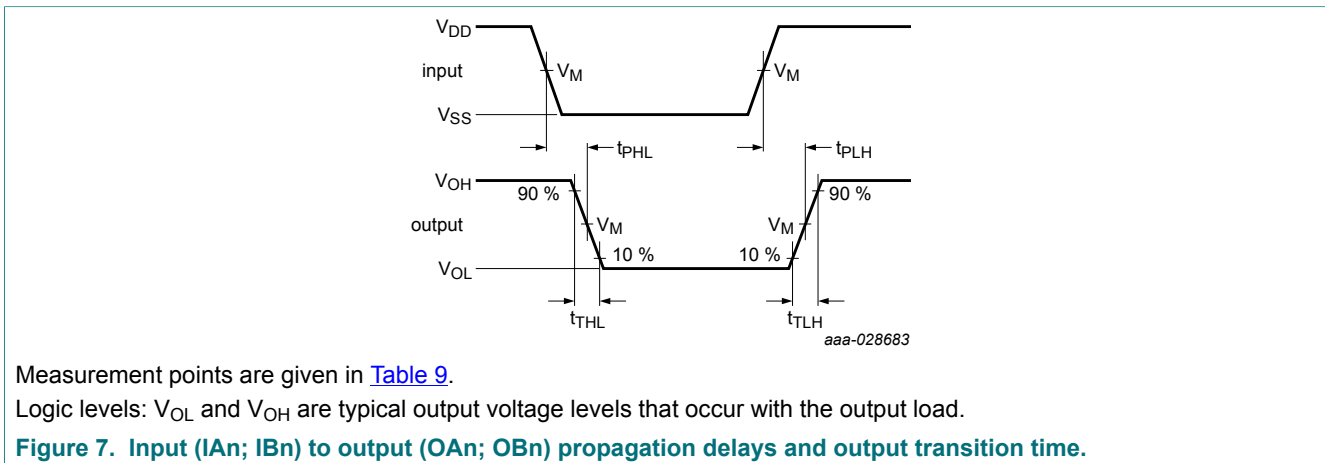
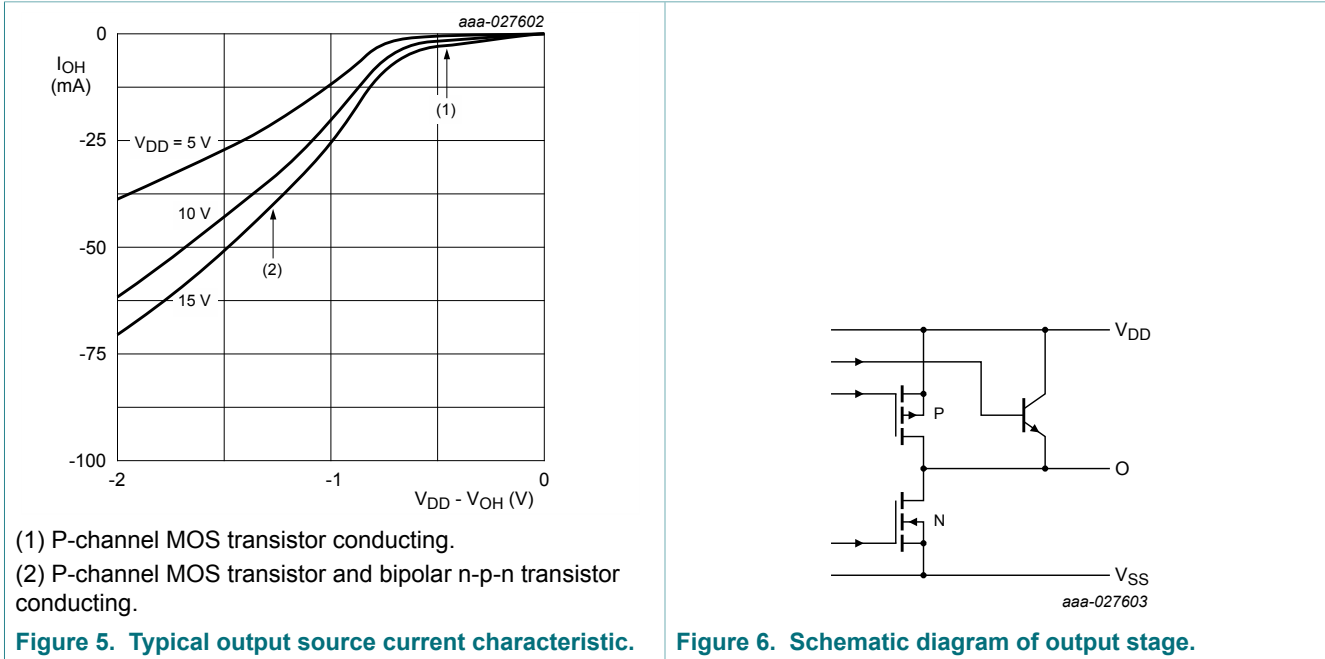

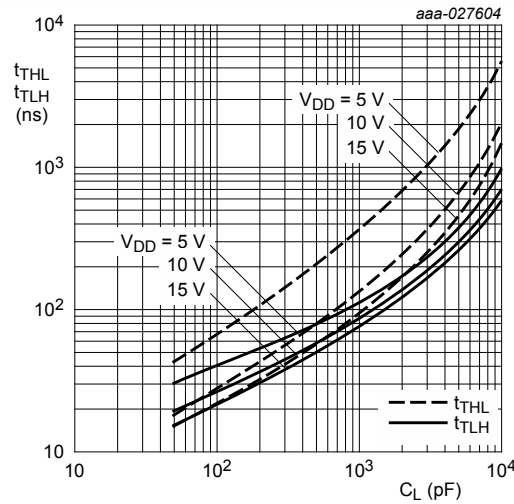
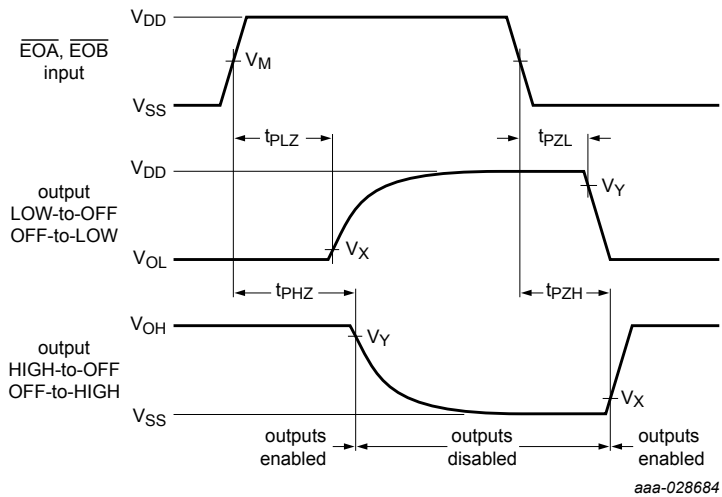

Figure 8. Output transition times as a function of the load capacitance



Measurement points are given in [Table 9](#).

Logic levels:  $V_{OL}$  and  $V_{OH}$  are typical output voltage levels that occur with the output load.

Figure 9. 3-state enable and disable times

Table 9. Measurement points

Supply voltage	Input	Output		
$V_{DD}$	$V_M$	$V_M$	$V_X$	$V_Y$
5 V to 15 V	$0.5V_{DD}$	$0.5V_{DD}$	$0.1V_{DD}$	$0.9V_{DD}$

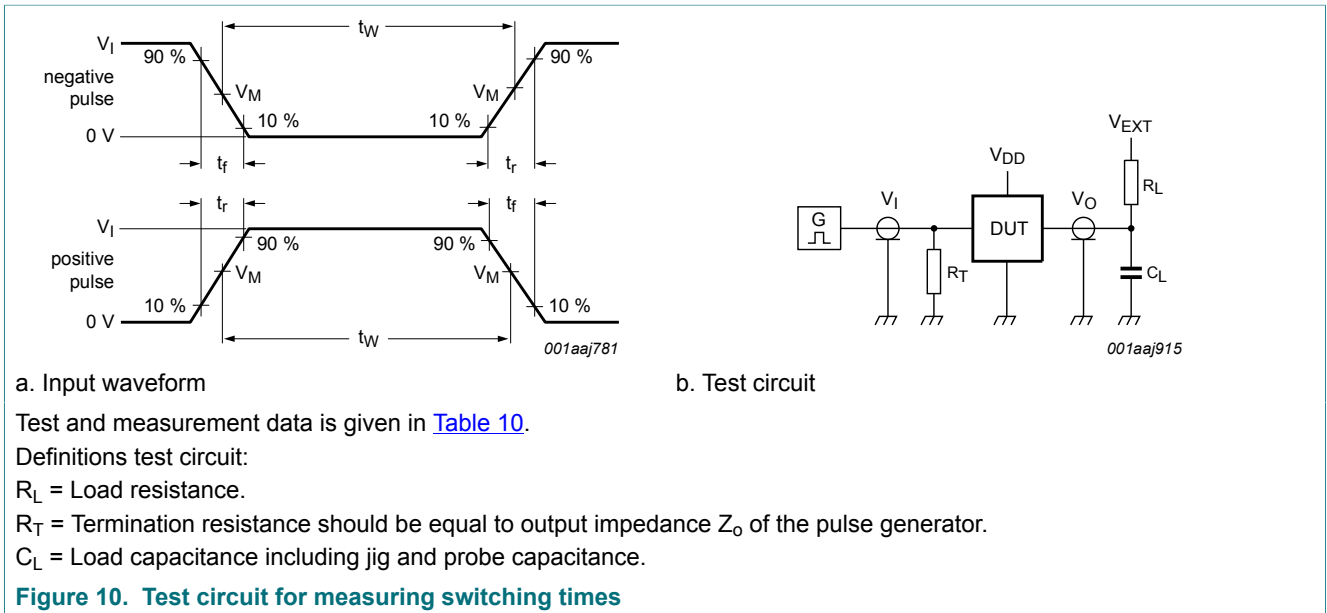

Table 10. Test data

Supply voltage	Input		Load		$V_{EXT}$		
$V_{DD}$	$V_I$	$t_r, t_f$	$C_L$	$R_L$	$t_{PLH}, t_{PHL}$	$t_{PHZ}, t_{PZH}$	$t_{PLZ}, t_{PZL}$
5 V to 15 V	$V_{DD}$	$\leq 20$ ns	50 pF	1 k $\Omega$	open	$V_{SS}$	$V_{DD}$

11 Package outline

SO20: plastic small outline package; 20 leads; body width 7.5 mm

SOT163-1

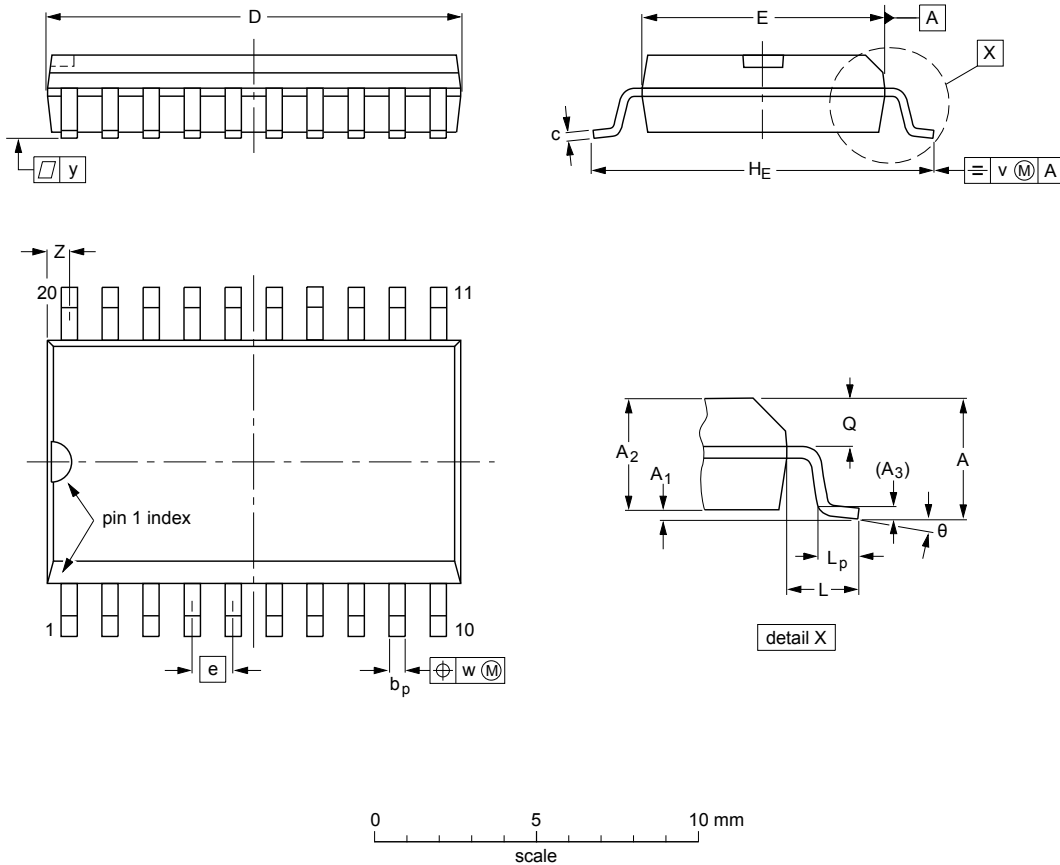

DIMENSIONS (inch dimensions are derived from the original mm dimensions)

UNIT	A max.	A <sub>1</sub>	A <sub>2</sub>	A <sub>3</sub>	b <sub>p</sub>	c	D <sup>(1)</sup>	E <sup>(1)</sup>	e	H <sub>E</sub>	L	L <sub>p</sub>	Q	v	w	y	Z <sup>(1)</sup>	θ
mm	2.65	0.3 0.1	2.45 2.25	0.25	0.49 0.36	0.32 0.23	13.0 12.6	7.6 7.4	1.27	10.65 10.00	1.4	1.1 0.4	1.1 1.0	0.25	0.25	0.1	0.9 0.4	8° 0°
inches	0.1	0.012 0.004	0.096 0.089	0.01	0.019 0.014	0.013 0.009	0.51 0.49	0.30 0.29	0.05	0.419 0.394	0.055	0.043 0.016	0.043 0.039	0.01	0.01	0.004	0.035 0.016	

Note

1. Plastic or metal protrusions of 0.15 mm (0.006 inch) maximum per side are not included.

OUTLINE VERSION	REFERENCES			EUROPEAN PROJECTION	ISSUE DATE
	IEC	JEDEC	JEITA		
SOT163-1	075E04	MS-013			99-12-27 03-02-19

Figure 11. Package outline SOT163-1 (SO20)

## 12 Abbreviations

Table 11. Abbreviations

Acronym	Description
DUT	Device Under Test

## 13 Revision history

Table 12. Revision history

Document ID	Release date	Data sheet status	Change notice	Supersedes
HEF40244B v.4	20180629	Product data sheet	-	HEF40244B v.3
Modifications:	<ul style="list-style-type: none"><li>The format of this data sheet has been redesigned to comply with the identity guidelines of Nexperia.</li><li>Legal texts have been adapted to the new company name where appropriate.</li></ul>			
HEF40244B v.3	19950101	Product specification	-	HEF40244B v.2
HEF40244B v.2	19950101	Product specification	-	HEF40244B v.1

## 14 Legal information

### 14.1 Data sheet status

Document status <sup>[1][2]</sup>	Product status <sup>[3]</sup>	Definition
Objective [short] data sheet	Development	This document contains data from the objective specification for product development.
Preliminary [short] data sheet	Qualification	This document contains data from the preliminary specification.
Product [short] data sheet	Production	This document contains the product specification.

[1] Please consult the most recently issued document before initiating or completing a design.

[2] The term 'short data sheet' is explained in section "Definitions".

[3] The product status of device(s) described in this document may have changed since this document was published and may differ in case of multiple devices. The latest product status information is available on the Internet at URL <http://www.nexperia.com>.

### 14.2 Definitions

**Draft** — The document is a draft version only. The content is still under internal review and subject to formal approval, which may result in modifications or additions. Nexperia does not give any representations or warranties as to the accuracy or completeness of information included herein and shall have no liability for the consequences of use of such information.

**Short data sheet** — A short data sheet is an extract from a full data sheet with the same product type number(s) and title. A short data sheet is intended for quick reference only and should not be relied upon to contain detailed and full information. For detailed and full information see the relevant full data sheet, which is available on request via the local Nexperia sales office. In case of any inconsistency or conflict with the short data sheet, the full data sheet shall prevail.

**Product specification** — The information and data provided in a Product data sheet shall define the specification of the product as agreed between Nexperia and its customer, unless Nexperia and customer have explicitly agreed otherwise in writing. In no event however, shall an agreement be valid in which the Nexperia product is deemed to offer functions and qualities beyond those described in the Product data sheet.

### 14.3 Disclaimers

**Limited warranty and liability** — Information in this document is believed to be accurate and reliable. However, Nexperia does not give any representations or warranties, expressed or implied, as to the accuracy or completeness of such information and shall have no liability for the consequences of use of such information. Nexperia takes no responsibility for the content in this document if provided by an information source outside of Nexperia. In no event shall Nexperia be liable for any indirect, incidental, punitive, special or consequential damages (including - without limitation - lost profits, lost savings, business interruption, costs related to the removal or replacement of any products or rework charges) whether or not such damages are based on tort (including negligence), warranty, breach of contract or any other legal theory. Notwithstanding any damages that customer might incur for any reason whatsoever, Nexperia's aggregate and cumulative liability towards customer for the products described herein shall be limited in accordance with the Terms and conditions of commercial sale of Nexperia.

**Right to make changes** — Nexperia reserves the right to make changes to information published in this document, including without limitation specifications and product descriptions, at any time and without notice. This document supersedes and replaces all information supplied prior to the publication hereof.

**Suitability for use** — Nexperia products are not designed, authorized or warranted to be suitable for use in life support, life-critical or safety-critical

systems or equipment, nor in applications where failure or malfunction of an Nexperia product can reasonably be expected to result in personal injury, death or severe property or environmental damage. Nexperia and its suppliers accept no liability for inclusion and/or use of Nexperia products in such equipment or applications and therefore such inclusion and/or use is at the customer's own risk.

**Applications** — Applications that are described herein for any of these products are for illustrative purposes only. Nexperia makes no representation or warranty that such applications will be suitable for the specified use without further testing or modification. Customers are responsible for the design and operation of their applications and products using Nexperia products, and Nexperia accepts no liability for any assistance with applications or customer product design. It is customer's sole responsibility to determine whether the Nexperia product is suitable and fit for the customer's applications and products planned, as well as for the planned application and use of customer's third party customer(s). Customers should provide appropriate design and operating safeguards to minimize the risks associated with their applications and products. Nexperia does not accept any liability related to any default, damage, costs or problem which is based on any weakness or default in the customer's applications or products, or the application or use by customer's third party customer(s). Customer is responsible for doing all necessary testing for the customer's applications and products using Nexperia products in order to avoid a default of the applications and the products or of the application or use by customer's third party customer(s). Nexperia does not accept any liability in this respect.

**Limiting values** — Stress above one or more limiting values (as defined in the Absolute Maximum Ratings System of IEC 60134) will cause permanent damage to the device. Limiting values are stress ratings only and (proper) operation of the device at these or any other conditions above those given in the Recommended operating conditions section (if present) or the Characteristics sections of this document is not warranted. Constant or repeated exposure to limiting values will permanently and irreversibly affect the quality and reliability of the device.

**Terms and conditions of commercial sale** — Nexperia products are sold subject to the general terms and conditions of commercial sale, as published at <http://www.nexperia.com/profile/terms>, unless otherwise agreed in a valid written individual agreement. In case an individual agreement is concluded only the terms and conditions of the respective agreement shall apply. Nexperia hereby expressly objects to applying the customer's general terms and conditions with regard to the purchase of Nexperia products by customer.

**No offer to sell or license** — Nothing in this document may be interpreted or construed as an offer to sell products that is open for acceptance or the grant, conveyance or implication of any license under any copyrights, patents or other industrial or intellectual property rights.

**Export control** — This document as well as the item(s) described herein may be subject to export control regulations. Export might require a prior authorization from competent authorities.

**Non-automotive qualified products** — Unless this data sheet expressly states that this specific Nexperia product is automotive qualified, the product is not suitable for automotive use. It is neither qualified nor tested in accordance with automotive testing or application requirements. Nexperia accepts no liability for inclusion and/or use of non-automotive qualified products in automotive equipment or applications. In the event that customer uses the product for design-in and use in automotive applications to automotive specifications and standards, customer (a) shall use the product without Nexperia's warranty of the product for such automotive applications, use and specifications, and (b) whenever customer uses the product for automotive applications beyond Nexperia's specifications such use shall be solely at customer's own risk, and (c) customer fully indemnifies Nexperia for any liability, damages or failed product claims resulting from customer

design and use of the product for automotive applications beyond Nexperia's standard warranty and Nexperia's product specifications.

**Translations** — A non-English (translated) version of a document is for reference only. The English version shall prevail in case of any discrepancy between the translated and English versions.

## 14.4 Trademarks

Notice: All referenced brands, product names, service names and trademarks are the property of their respective owners.

## Contents

<b>1</b>	<b>General description .....</b>	<b>1</b>
<b>2</b>	<b>Features and benefits .....</b>	<b>1</b>
<b>3</b>	<b>Ordering information .....</b>	<b>1</b>
<b>4</b>	<b>Functional diagram .....</b>	<b>2</b>
<b>5</b>	<b>Pinning information .....</b>	<b>2</b>
5.1	Pinning .....	2
5.2	Pin description .....	3
<b>6</b>	<b>Functional description .....</b>	<b>3</b>
<b>7</b>	<b>Limiting values .....</b>	<b>3</b>
<b>8</b>	<b>Recommended operating conditions .....</b>	<b>4</b>
<b>9</b>	<b>Static characteristics .....</b>	<b>4</b>
<b>10</b>	<b>Dynamic characteristics .....</b>	<b>5</b>
10.1	Waveforms and test circuit .....	7
<b>11</b>	<b>Package outline .....</b>	<b>10</b>
<b>12</b>	<b>Abbreviations .....</b>	<b>11</b>
<b>13</b>	<b>Revision history .....</b>	<b>11</b>
<b>14</b>	<b>Legal information .....</b>	<b>12</b>

---

Please be aware that important notices concerning this document and the product(s) described herein, have been included in section 'Legal information'.

---

© Nexperia B.V. 2018.

All rights reserved.

For more information, please visit: <http://www.nexperia.com>

For sales office addresses, please send an email to: [salesaddresses@nexperia.com](mailto:salesaddresses@nexperia.com)

Date of release: 29 June 2018  
Document identifier: HEF40244B